



Farabaugh Engineering and Testing Inc.

Project No. T101-16

Report Date: January 13, 2016

Total No. of Pages: 10

PERFORMANCE TEST REPORT

ASTM E72-02 CONCENTRATED HORIZONTAL LOAD TEST (MODIFIED)

ON

QUICK SLING SUPER STAND
(TYPE C MODEL - QSSS1005)

FOR

QUICK SLING, LLC
391 W. WATER STREET
TAUTON, MA. 02780

Report Prepared By:

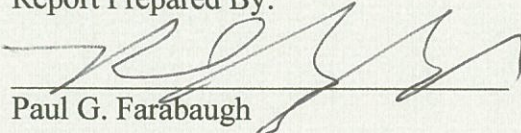
Paul G. Farabaugh

Reviewed and Approved By:

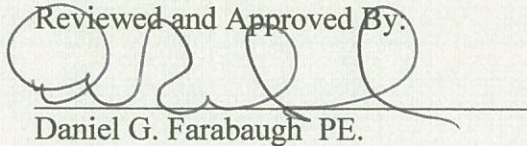
Daniel G. Farabaugh PE.

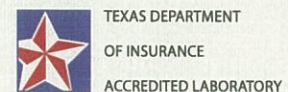
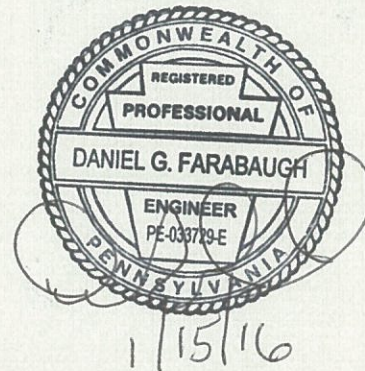

Project No. T101-16

Introduction

Concentrated load test was conducted on the specified date at Farabaugh Engineering and Testing facility in McKeesport, PA. A description and summary of that test are contained here-in.

Purpose

The purpose of the testing was to determine the structural performance of the Super Stand under concentrated horizontal loads.

Manufacturer

Quick Sling, LLC
391 W. Water Street
Tauton, MA. 02780

Specimen: SUPER STAND - TYPE C (Model - QSSS1005) for the 12" , 18" and 24" high stands

Test Date: 1/12/2016

Test Assembly

The test assembly was as shown on the attached sketches. Stand was mounted to wood base using (2) 3/8" diameter bolts at each steel base.. Information on the test conducted in this report may be found on the attached data sheets.

Test Procedure

The test procedure was per ASTM E72-02 "Standard Test Methods of Conducting Strength Tests of Panels for Building Construction", Concentrated Load (modified as provided here-in). A pneumatic ram provided loading to the test assembly. The load was applied in a horizontal direction at quarter points along the test member. A calibrated load cell was used to monitor the loading increments. Deflectometers were used to measure the deflection of the specimens as shown on the attached drawings. Test loads were applied incrementally while deflection data was recorded as shown on the attached data sheets.

Project No. T101-16

TEST DATA

Test Date: 1-12-16

Manufacturer: Quick Sling LLC

Test Specimen: SUPER STAND - TYPE C (Model - QSSS1005) for the 12" high stand

Ht. of SS = 11-5/8"

HT of P = 12-3/8"

(Ht from base to underside of Super Stand) (Height from base to center of test load)

TEST RESULTS

Test #12S

CONDITION: Load was applied in the short direction @ quarter points.

QUICK SLING 12" SUPER STAND MODEL NO. QSSS1005 (TYPE C SINGLE)
TEST #12S SHORT DIRECTION

P - LOAD (LB)	DIAL 1	DIAL 2
0	0.000	0.000
589	0.142	0.142
0	0.021	0.028
884	0.240	0.244
0	0.046	0.059
1178	0.335	0.353
0	0.065	0.080
1472	0.435	0.476
0	0.086	0.106

Test #12L

CONDITION: Load was applied in the long direction @ quarter points

QUICK SLING 12" SUPER STAND MODEL NO. QSSS1005 (TYPE C SINGLE)
TEST #12L LONG DIRECTION

P - LOAD (LB)	DIAL 1	DIAL 2
0	0.000	0.000
589	0.342	0.376
0	0.051	0.054
884	0.515	0.555
0	0.080	0.086
1178	0.682	0.733
0	0.112	0.120
1472	0.865	0.924
0	0.195	0.201

Project No. T101-16

TEST DATA

Test Date: 1-12-16

Manufacturer: Quick Sling LLC

Test Specimen: SUPER STAND-TYPE C (Model-QSSS1005-18") for the 18" high stand

Ht. of SS = 18-7/8"

HT of P = 19-5/8"

(Ht from base to underside of Super Stand) (Height from base to center of test load)

TEST RESULTS

Test #18S

CONDITION: Load was applied in the short direction @ quarter points

QUICK SLING 18" SUPER STAND MODEL NO. QSSS1005-18 (TYPE C SINGLE)

TEST #18S SHORT DIRECTION

P - LOAD (LB)	DIAL 1	DIAL 2
0	0.000	0.000
589	0.333	0.358
0	0.041	0.055
884	0.516	0.560
0	0.065	0.072
1178	0.707	0.767
0	0.094	0.091
1472	0.897	0.979
0	0.134	0.129

Test #18L

CONDITION: Load was applied in the long direction @ quarter points

QUICK SLING 18" SUPER STAND MODEL NO. QSSS1005-18 (TYPE C SINGLE)

TEST #18L LONG DIRECTION

P - LOAD (LB)	DIAL 1	DIAL 2
0	0.000	0.000
589	0.680	0.712
0	0.130	0.145
884	0.961	1.026
0	0.218	0.247
1178	1.227	1.311
0	0.296	0.332
1472	1.509	1.605
0	0.322	0.360

Project No. T101-16

TEST DATA

Test Date: 1-12-16

Manufacturer: Quick Sling LLC

Test Specimen: SUPER STAND-TYPE C (Model-QSSS1005-24") for the 24" high stand

Ht. of SS = 25"

HT of P = 25-3/4"

(Ht from base to underside of Super Stand) (Height from base to center of test load)

TEST RESULTS

Test #24S

CONDITION: Load was applied in the short direction @ quarter points

QUICK SLING 24" SUPER STAND MODEL NO. QSSS1005-24 (TYPE C SINGLE)

TEST #24S SHORT DIRECTION

P - LOAD (LB)	DIAL 1	DIAL 2
0	0.000	0.000
589	0.320	0.343
0	0.040	0.044
884	0.530	0.589
0	0.069	0.077
1178	0.752	0.847
0	0.107	0.116
1472	0.980	1.109
0	0.149	0.154

Test #24L

CONDITION: Load was applied in the long direction @ quarter points

QUICK SLING 24" SUPER STAND MODEL NO. QSSS1005-24 (TYPE C SINGLE)

TEST #24L LONG DIRECTION

P - LOAD (LB)	DIAL 1	DIAL 2
0	0.000	0.000
589	0.718	0.689
0	0.113	0.132
884	1.063	1.118
0	0.181	0.232
1178	1.438	1.510
0	0.319	0.329
1472	1.849	1.936
0	0.439	0.503

TEST SETUP IN LONG DIRECTION

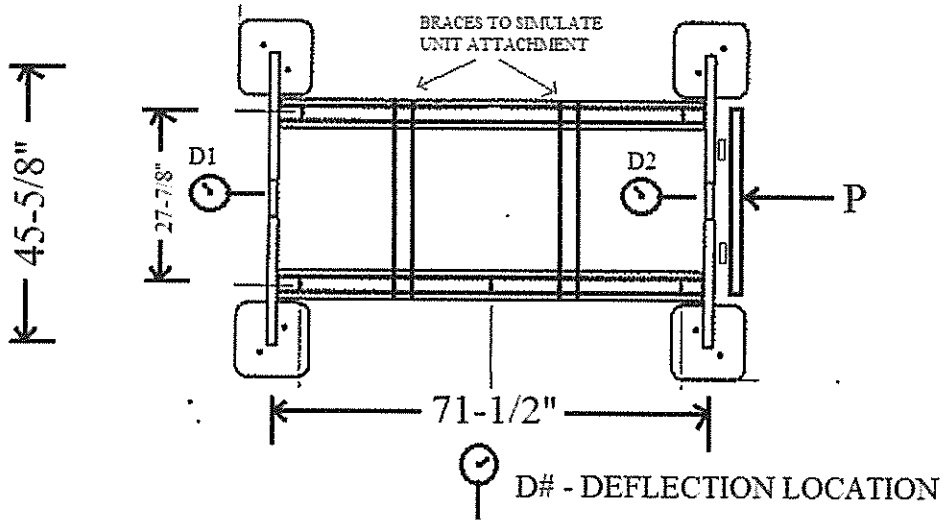

PLAN VIEW

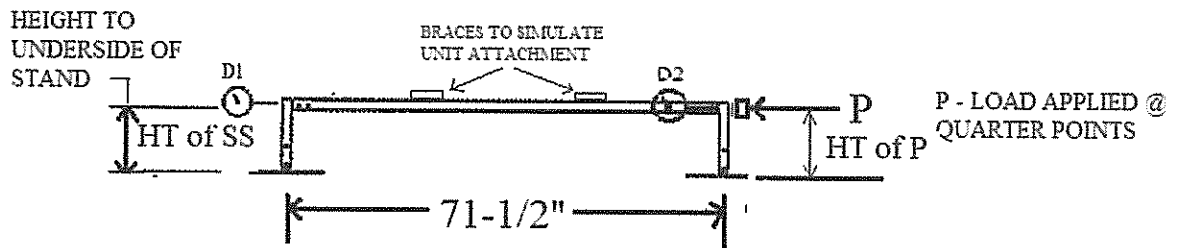

LONG DIRECTION TESTED
ELEVATION VIEW

HT of SS - Height of Super Stand from the top of the steel base to the bottom underside of the stand.

HT of P - Height of P (Load) from the top of the steel base to the center of the test load.

TEST SETUP IN SHORT DIRECTION

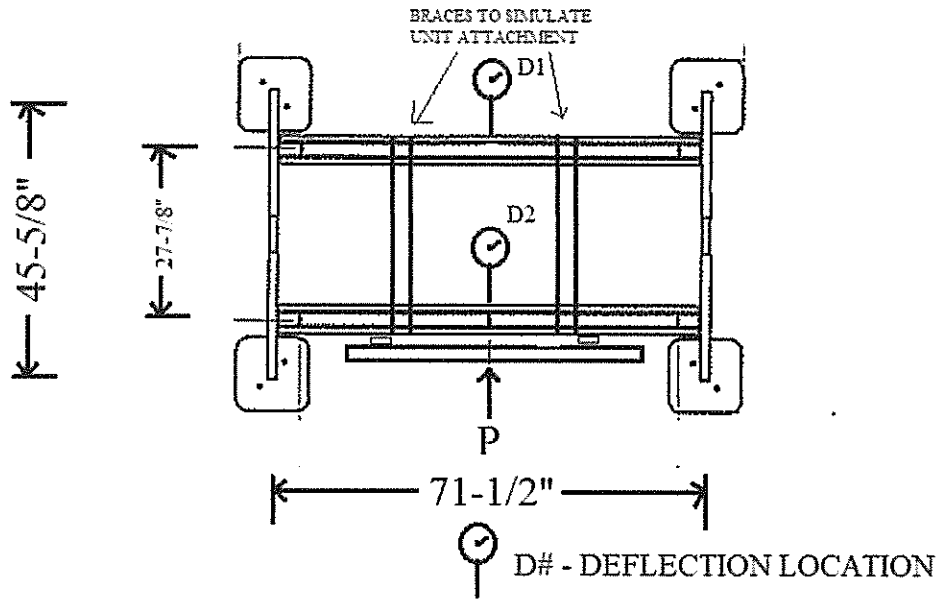

PLAN VIEW

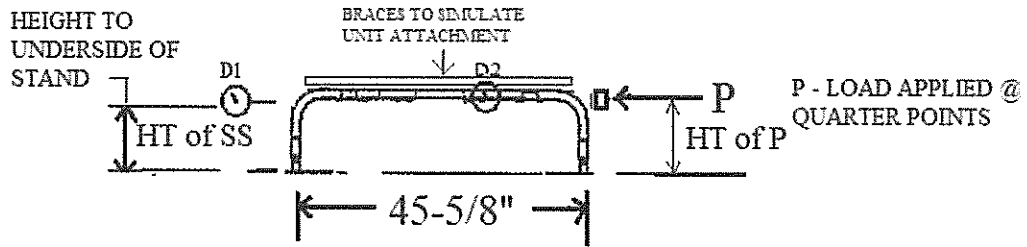

SHORT DIRECTION TESTED
ELEVATION VIEW

HT of SS - Height of Super Stand from the top of the steel base to the bottom underside of the stand.

HT of P - Height of P (Load) from the top of the steel base to the center of the test load.

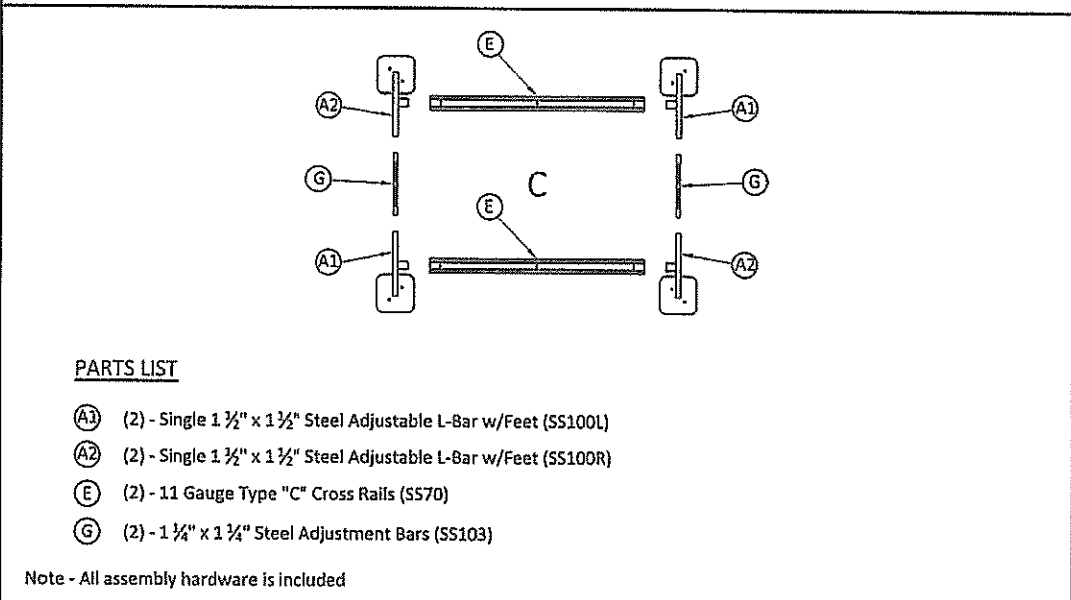
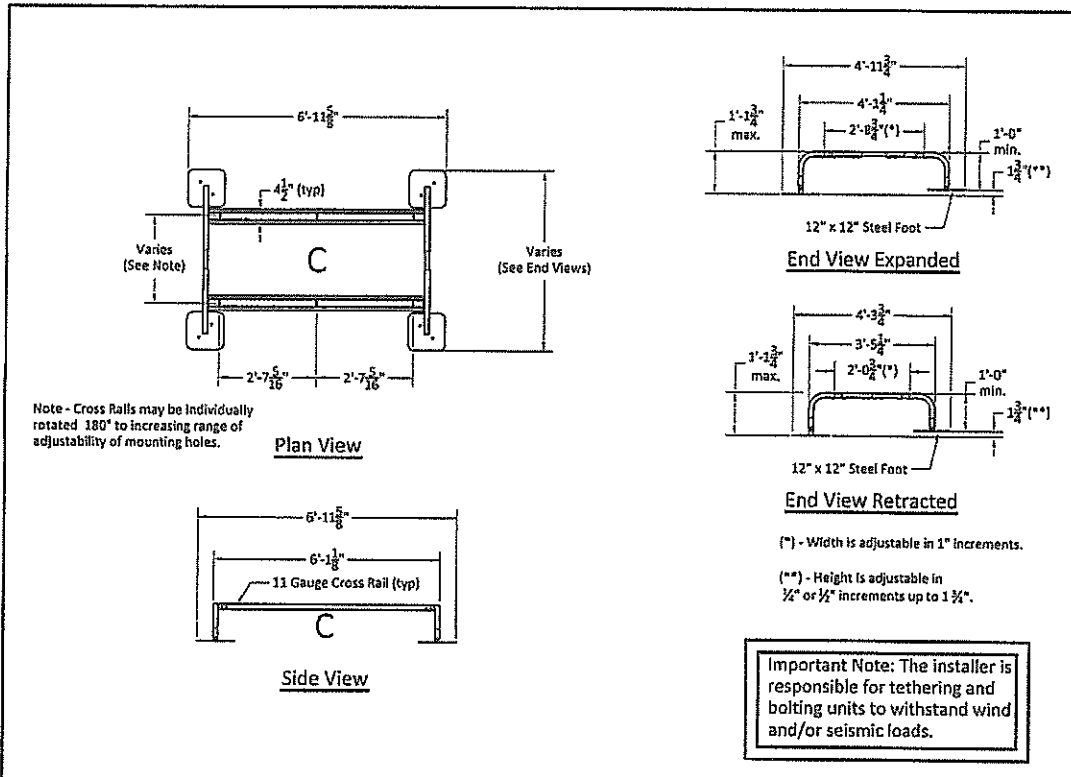

	<p>SUPER STAND - TYPE C MODEL NO. QSSS1005 U.S. Patent No. 866,754</p>	<p>www.quick-sling.com email: info@quick-sling.com fax: 1-(800)-699-0423</p>	<p>Quick Sling, LLC 391 W. Water Street Taunton, MA 02780 1-(800)-699-0453</p>
--	--	--	---

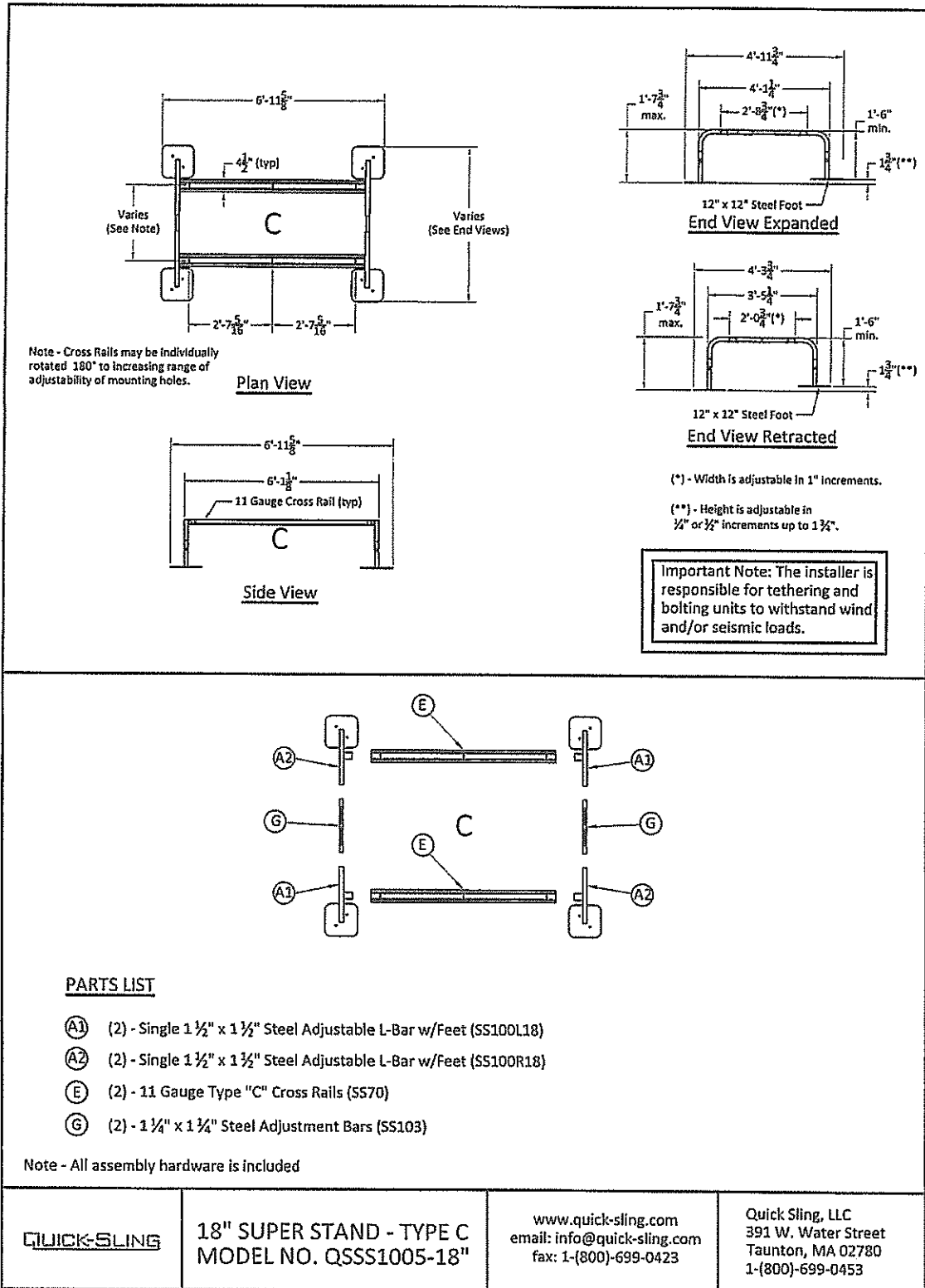

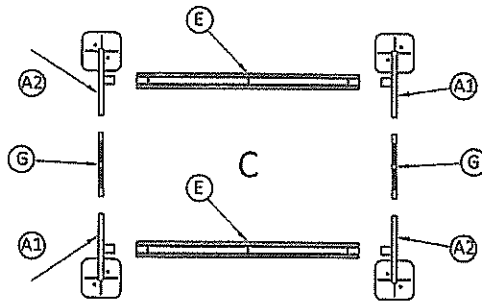
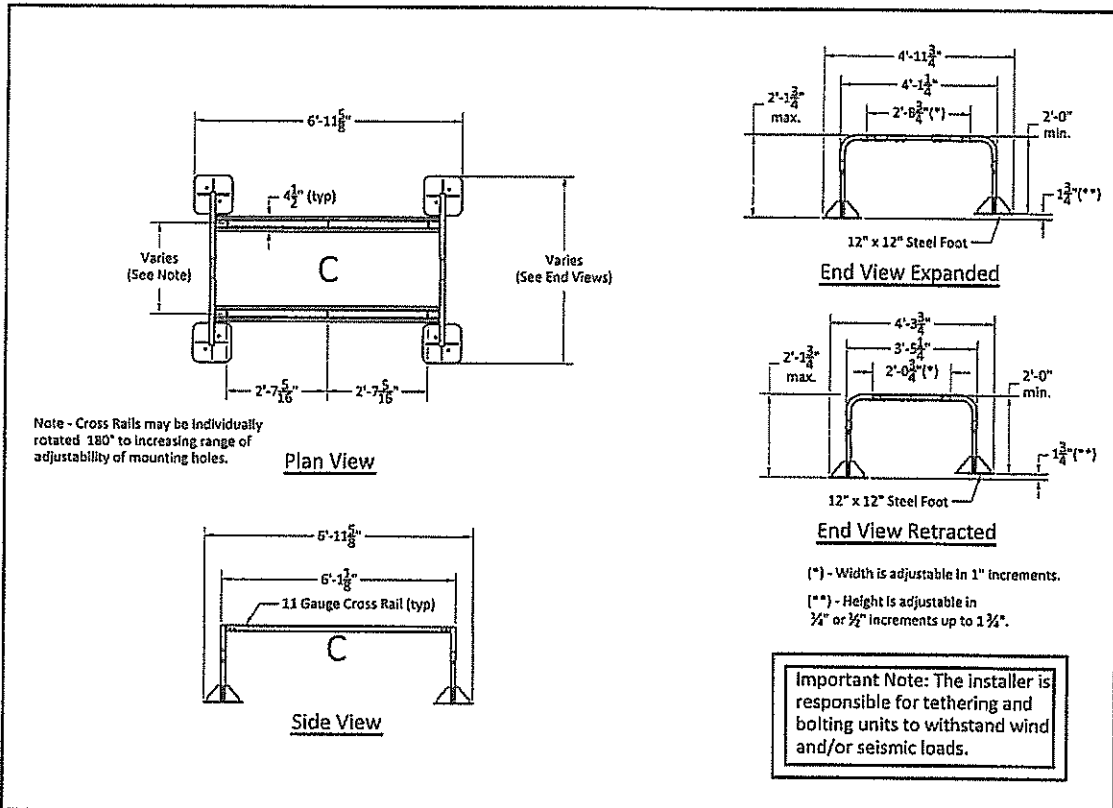

PARTS LIST

- (A1) (2) - Single 1 1/2" x 1 1/2" Steel Adjustable L-Bar w/Feet (SS100L24)
- (A2) (2) - Single 1 1/2" x 1 1/2" Steel Adjustable L-Bar w/Feet (SS100R24)
- (E) (2) - 11 Gauge Type "C" Cross Rails (SS70)
- (G) (2) - 1 1/4" x 1 1/4" Steel Adjustment Bars (SS103)

Note - All assembly hardware is included

	<p>24" SUPER STAND - TYPE C MODEL NO. QSSS1005-24"</p>	<p>www.quick-sling.com email: info@quick-sling.com fax: 1-(800)-699-0423</p>	<p>Quick Sling, LLC 391 W. Water Street Taunton, MA 02780 1-(800)-699-0453</p>
--	---	--	---