

PLAN VIEW RETRACTED

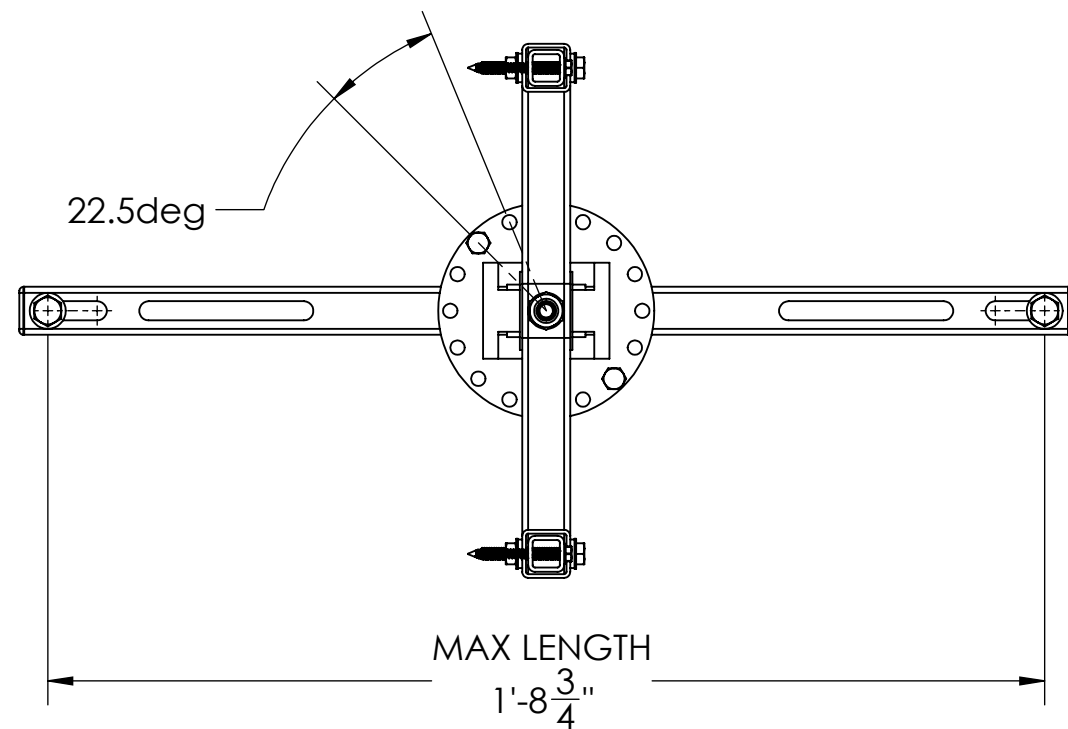

PLAN VIEW EXPANDED

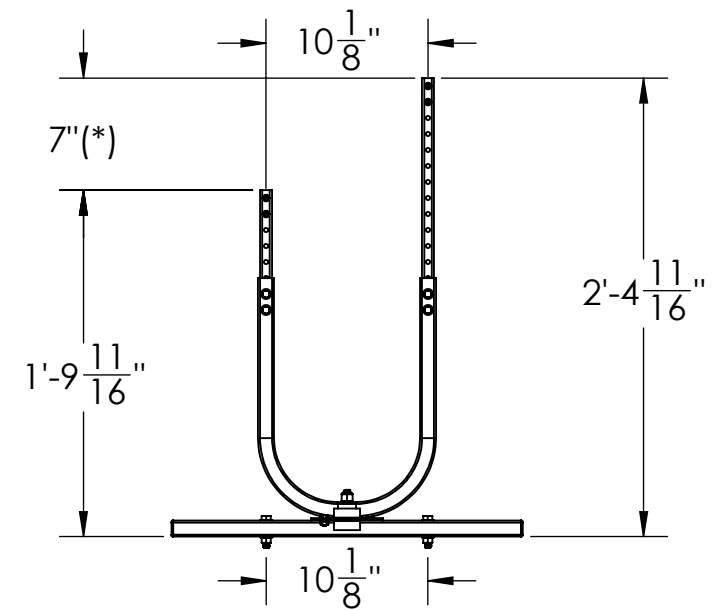

END VIEW RETRACTED

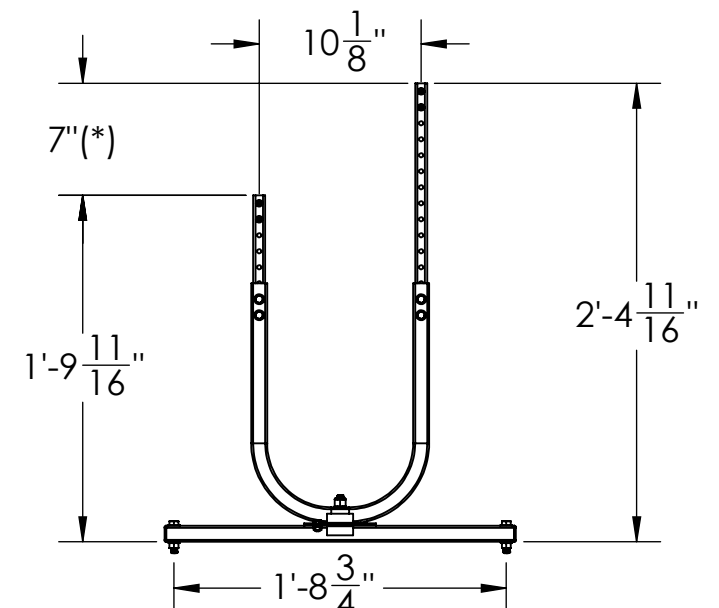

END VIEW EXPANDED

(*) - HEIGHT IS ADJUSTABLE IN 1" INCREMENTS UP TO 7".

IMPORTANT NOTE: THE INSTALLER IS RESPONSIBLE FOR THETHERING AND BOLTING UNITS TO WITHSTAND WIND AND/OR SEISMIC LOADS.

UNLESS OTHERWISE SPECIFIED:
 DIMENSIONS ARE IN INCHES [MILLIMETERS]
 TOLERANCES ARE: ANGLES ±1.0°
 FRACTIONAL SIZES X/Y ±1/64

INCHES	[MILLIMETERS]
X = ±0.1	[X = ± 2.5]
.XX = ±0.01	[.X = ± 1.3]
.XXX = ±0.005	[.XX = ±0.13]

THIRD ANGLE PROJECTION



CONFIDENTIAL - PROPRIETARY - DO NOT COPY THE INFORMATION SET FORTH IN THIS DOCUMENT AND RELATED INFORMATION IS THE CONFIDENTIAL PROPERTY OF DIVERSITECH CORPORATION, AND IS NOT TO BE COPIED OR REPRODUCED OR DISTRIBUTED IN ANY FORM WITHOUT PRIOR WRITTEN PERMISSION FROM DIVERSITECH CORPORATION. DO NOT SCALE DRAWING	MATERIAL: DWG. NO. Quick Swivel - 2000	WEIGHT GMS. REV.
	DESCRIPTION: MODEL NO. QSWI-2000	SHEET 1 OF 2

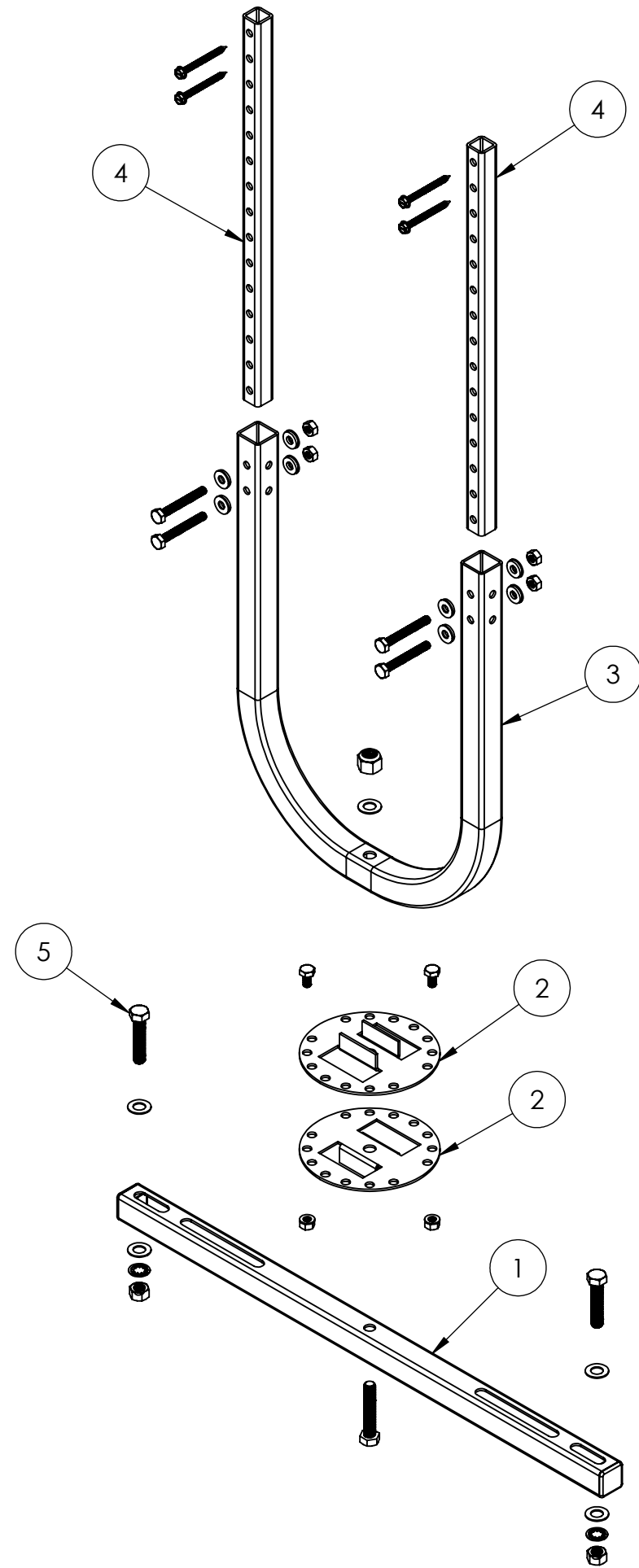

ITEM NO.	PART NUMBER	DESCRIPTION	Default/ QTY.
1	SW102	Swivel I-Bar	1
2	SW100	Swivel Circular Adjust Plate	2
3	SW105	Swivel U-Bar	1
4	SW104	Swivel Left & Right Hanger Arm	2
5	HDKWI02	Hardware kit for QSWI2000	1

NOTE - ALL ASSEMBLY HARDWARE IS INCLUDED

UNLESS OTHERWISE SPECIFIED:
 DIMENSIONS ARE IN INCHES [MILLIMETERS]
 TOLERANCES ARE: ANGLES ±1.0°
 FRACTIONAL SIZES X/Y ±1/64

INCHES	[MILLIMETERS]
X = ±0.1	[X = ± 2.5]
.XX = ±0.01	[.X = ± 1.3]
.XXX = ±0.005	[.XX = ±0.13]

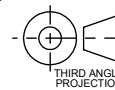

CONFIDENTIAL - PROPRIETARY - DO NOT COPY THE INFORMATION SET FORTH IN THIS DOCUMENT AND RELATED INFORMATION IS THE CONFIDENTIAL PROPERTY OF DIVERSITECH CORPORATION, AND IS NOT TO BE COPIED OR REPRODUCED OR DISTRIBUTED IN ANY FORM WITHOUT PRIOR WRITTEN PERMISSION FROM DIVERSITECH CORPORATION. DO NOT SCALE DRAWING	MATERIAL: DWG. NO. Quick Swivel - 2000 MODEL NO. QSWI-2000	WEIGHT GMS. REV.
	DESCRIPTION	SHEET 2 OF 2